





Condition for is IFP pulse: Pulse Width 100 $\mu$ s and duty 1%.

--	--	--	--

LIGHT

LIGHT ELECTRONICS CO., LTD.



--	--	--	--

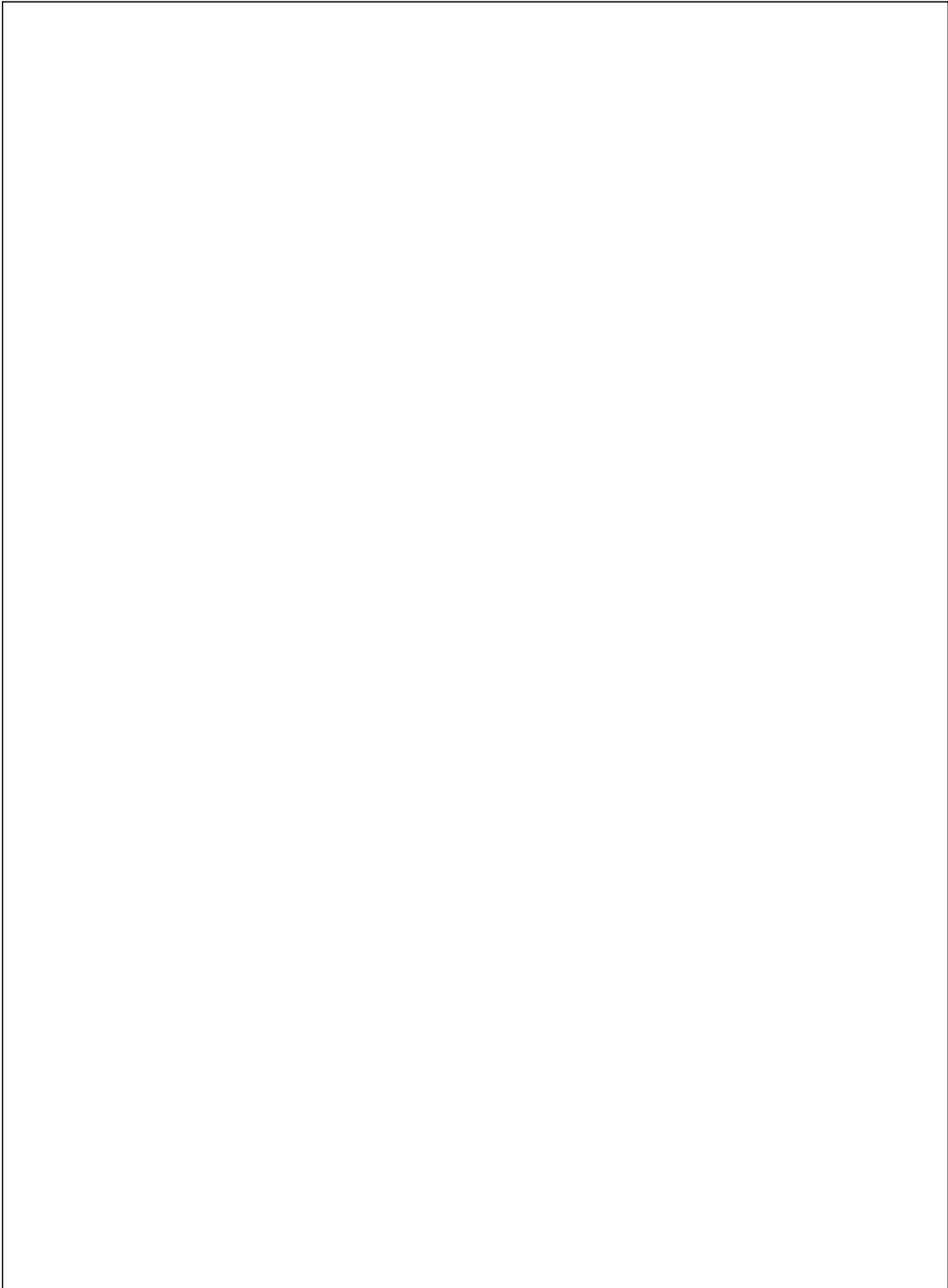

L

LIGHT ELECTRONICS CO., LTD.







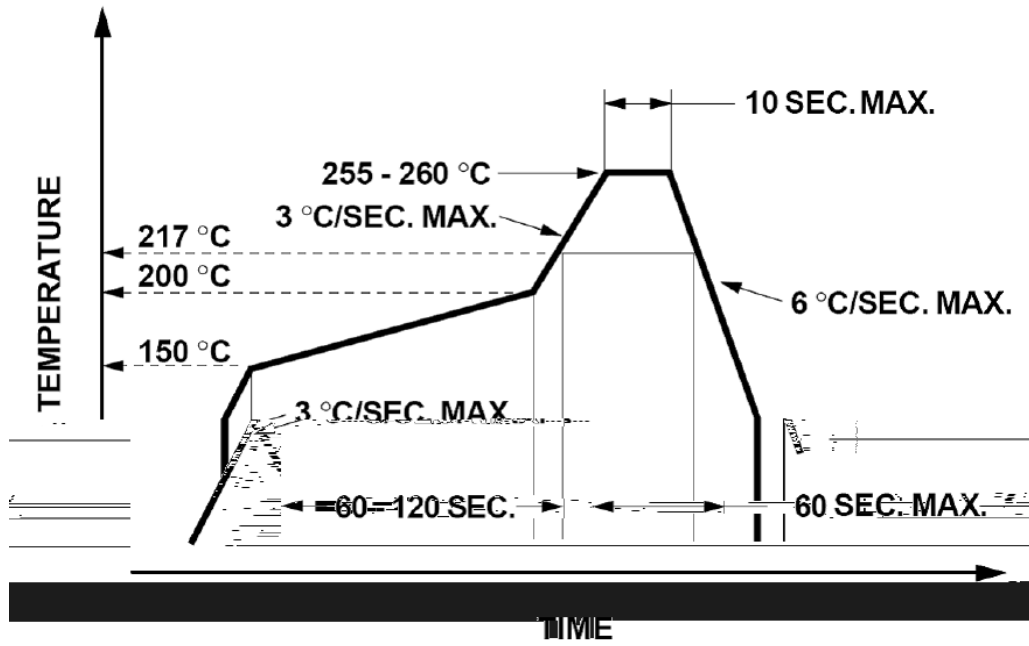

°C

