

# SL-T0603PTC020-L55-A

## DATA SHEET

SPEC. NO. : SZ20073001  
DATE : 2020/07/30  
REV. : A/0

Approved By:

Checked By:

Prepared By:

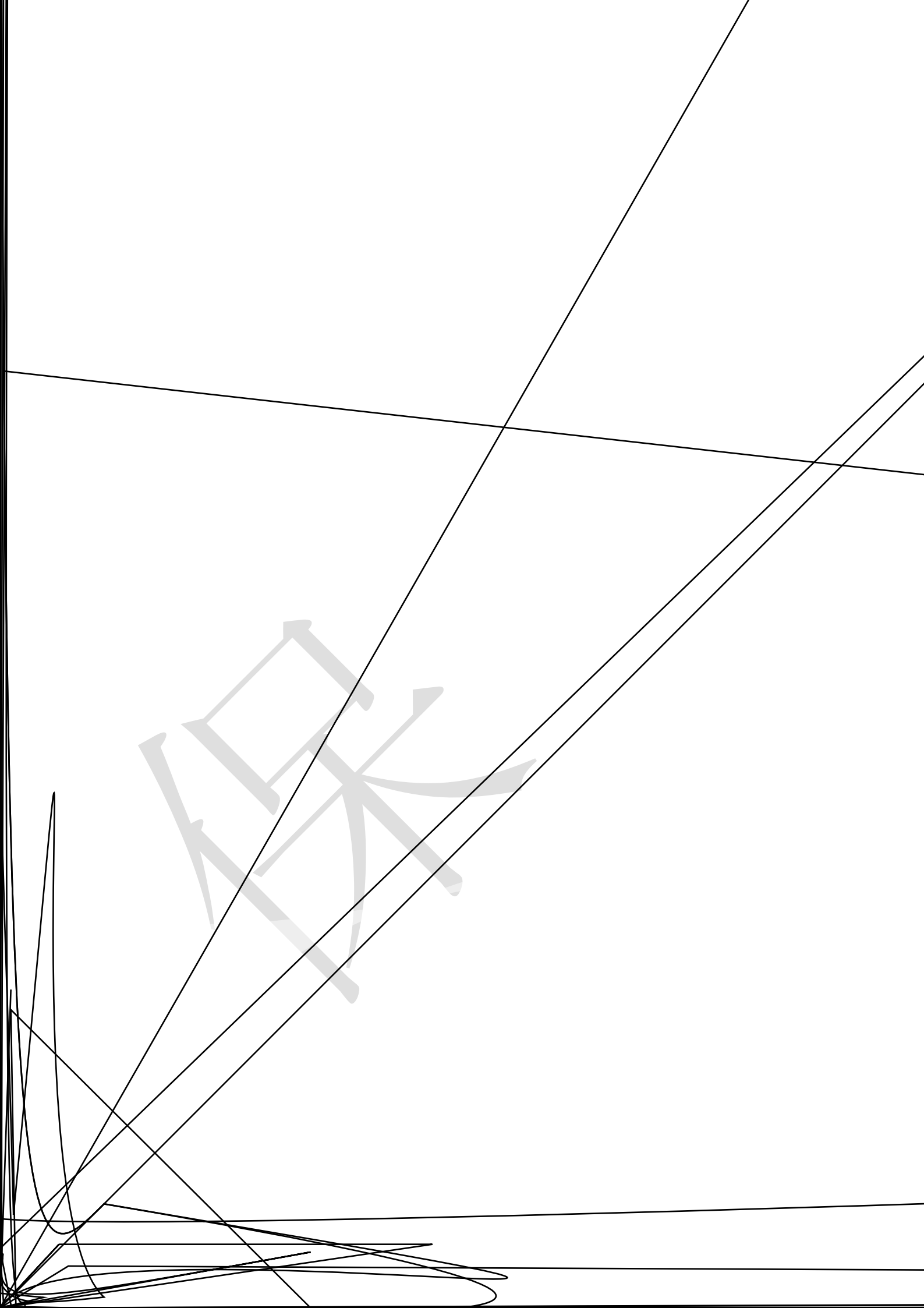



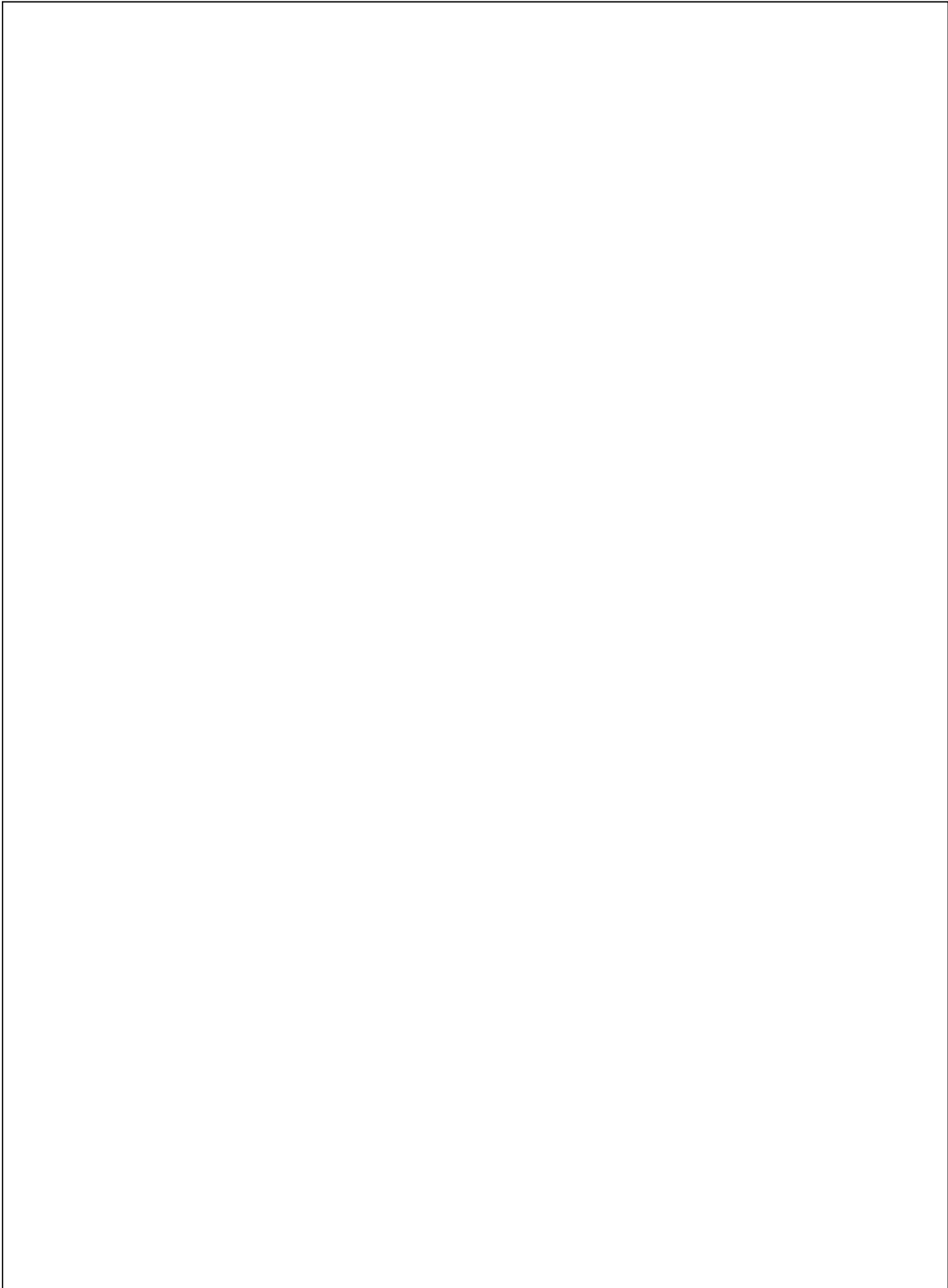

## Typical Electrical / Optical Characteristics Curves (25 W Ambient Temperature Unless Otherwise Noted)

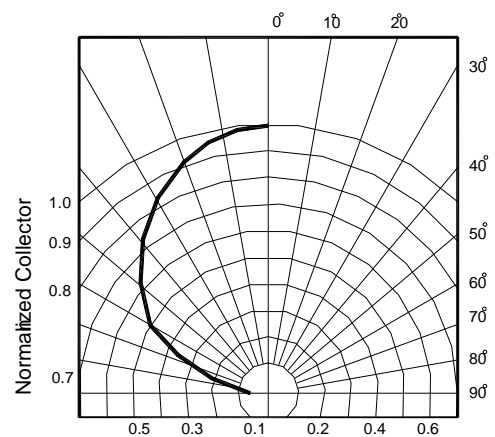
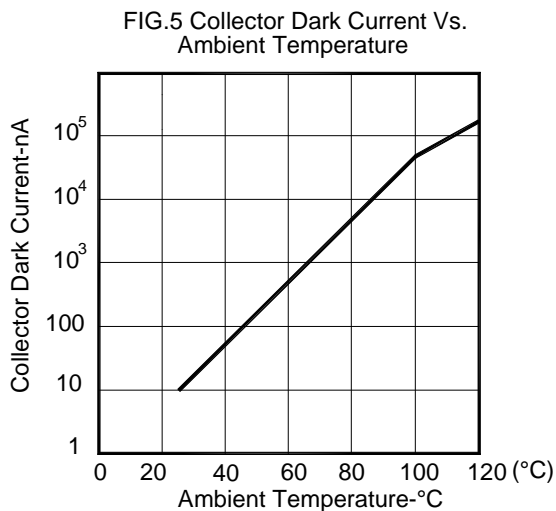
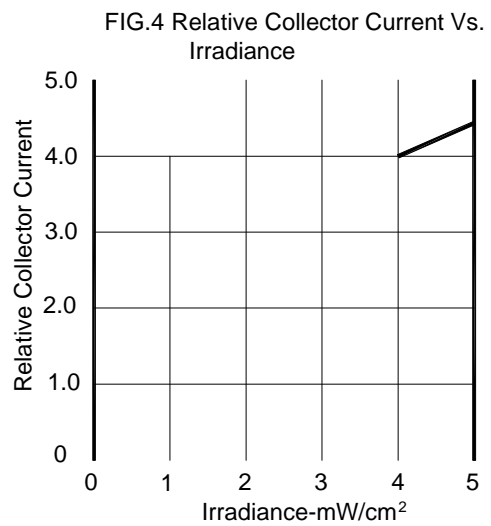
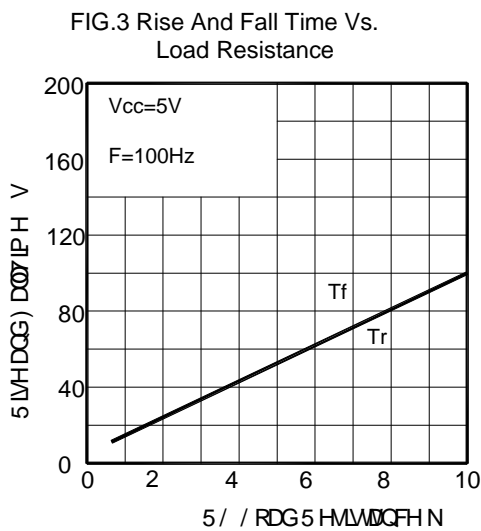
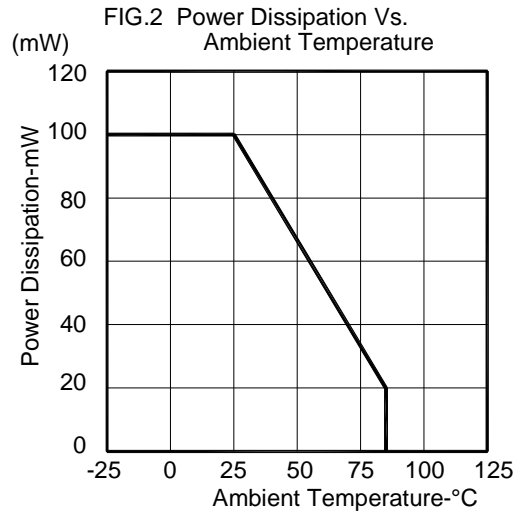
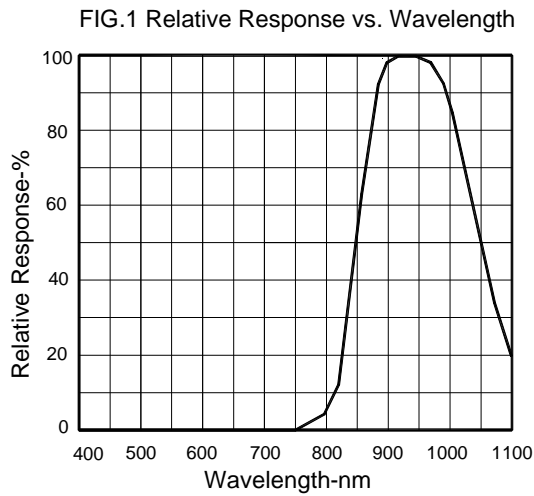





## Carrier Tape Specifications (Loaded Quantity: 5000pcs/reel)

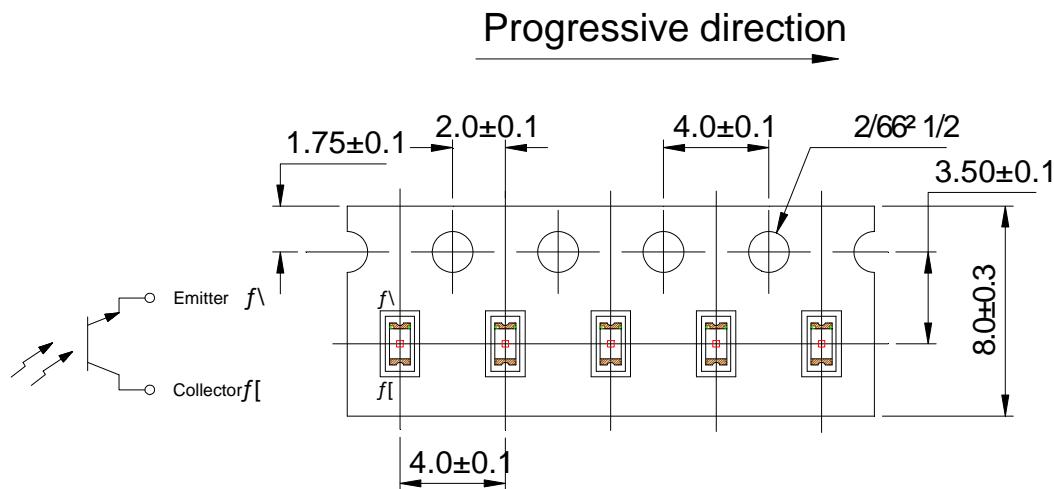

Note: Tolerance unless mentioned is  $\pm 0.1$ mm; Unit = mm

## Moisture Resistant Packaging

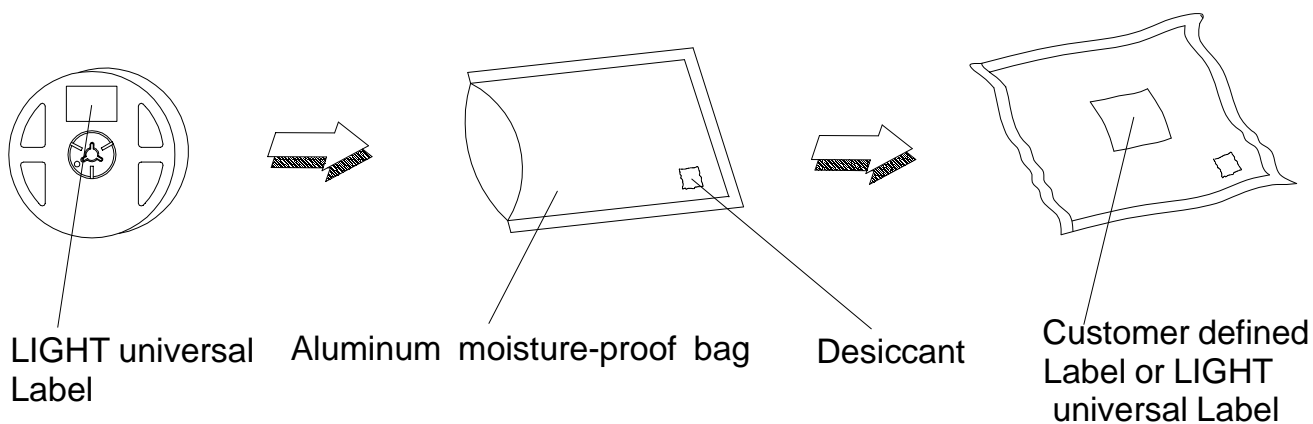

## Suggest IR Reflow Condition For Lead Free

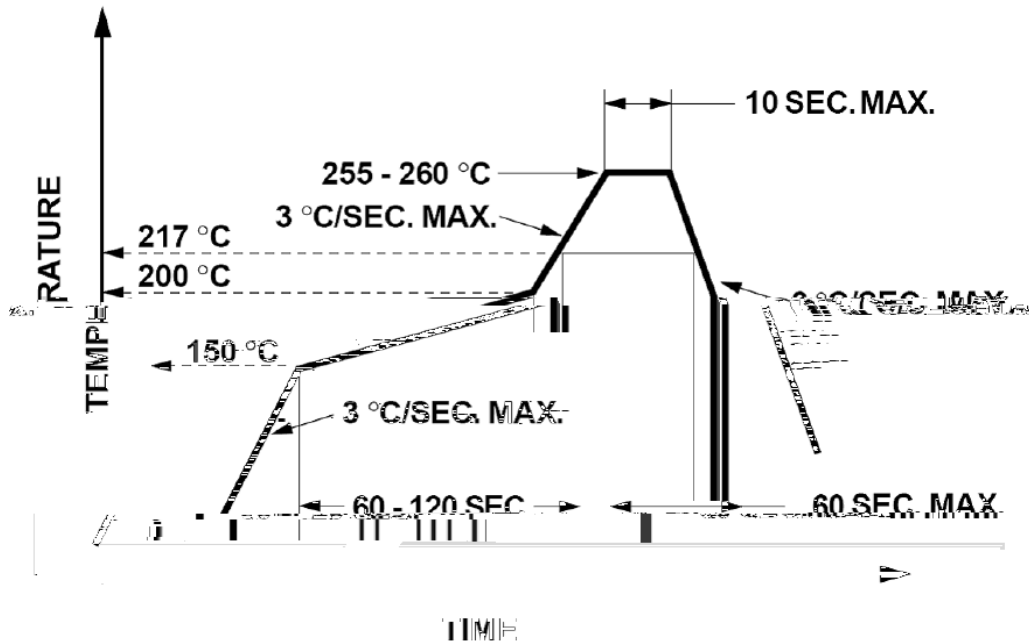

1. Reflow soldering should not be done more than two times.
2. When soldering, do not put stress on the LEDs during heating.

## Soldering iron

1. When hand soldering, the temperature of the iron must less than ~~300~~ 300 seconds
2. The hand solder should be done only once.

## Repairing

Repair should not be done after the LEDs have been soldered. When repairing is unavoidable, a double-head soldering iron should be used (as below figure). It should be confirmed beforehand whether the characteristics of LEDs will or will not be damaged by repairing.

