

LG-IRM2A638KEF3

Infrared Receiver Module

DATA SHEET

SPEC.NO. : SZ19070801
DATE : 2017/07/08
REV. : A/0

Approved By:

Checked By:

Prepared By:

LI**G**H**T**

LIGHT ELECTRONICS CO., LTD.

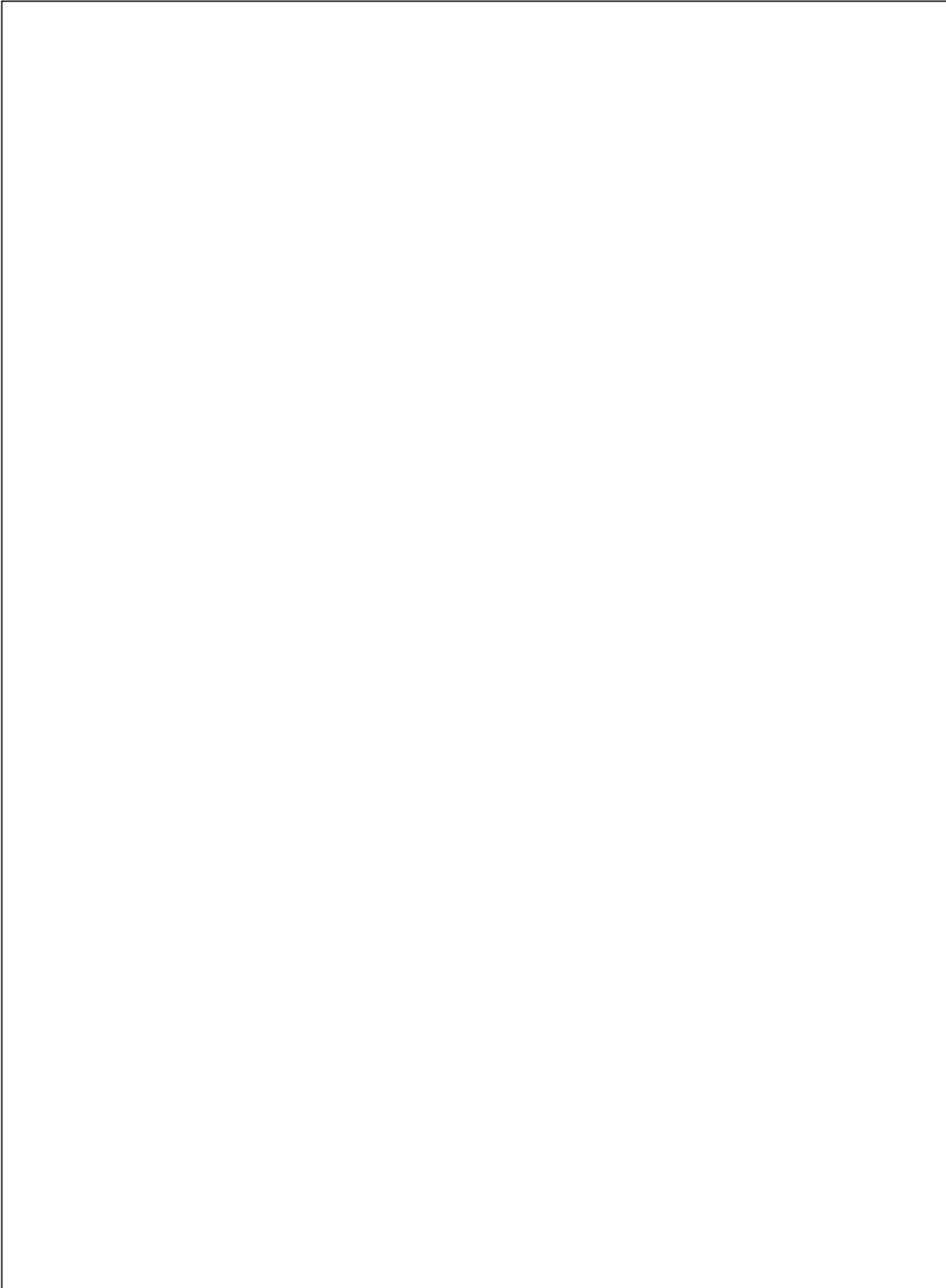

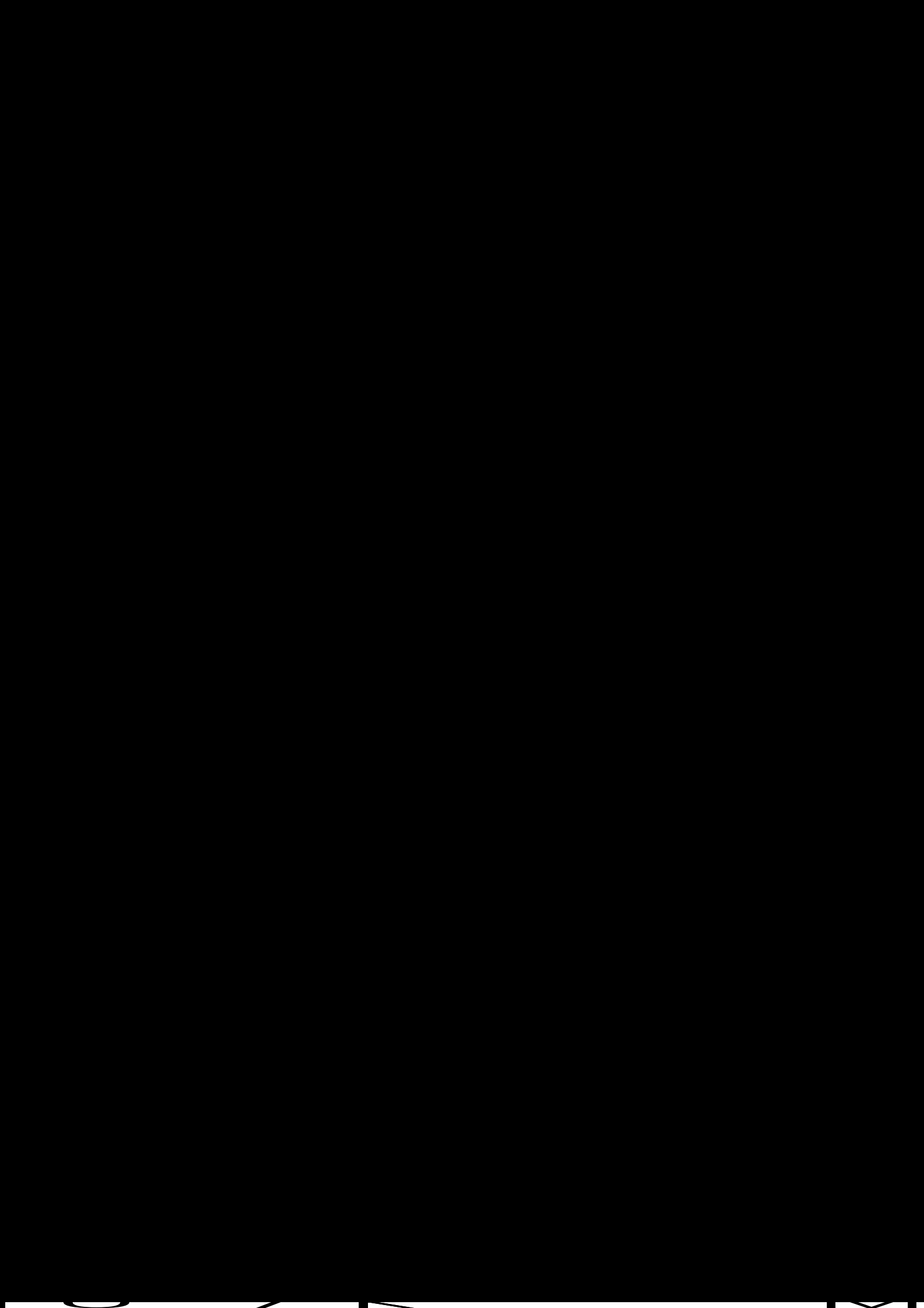

LI**G**H**T**

LIGHT ELECTRONICS CO., LTD.

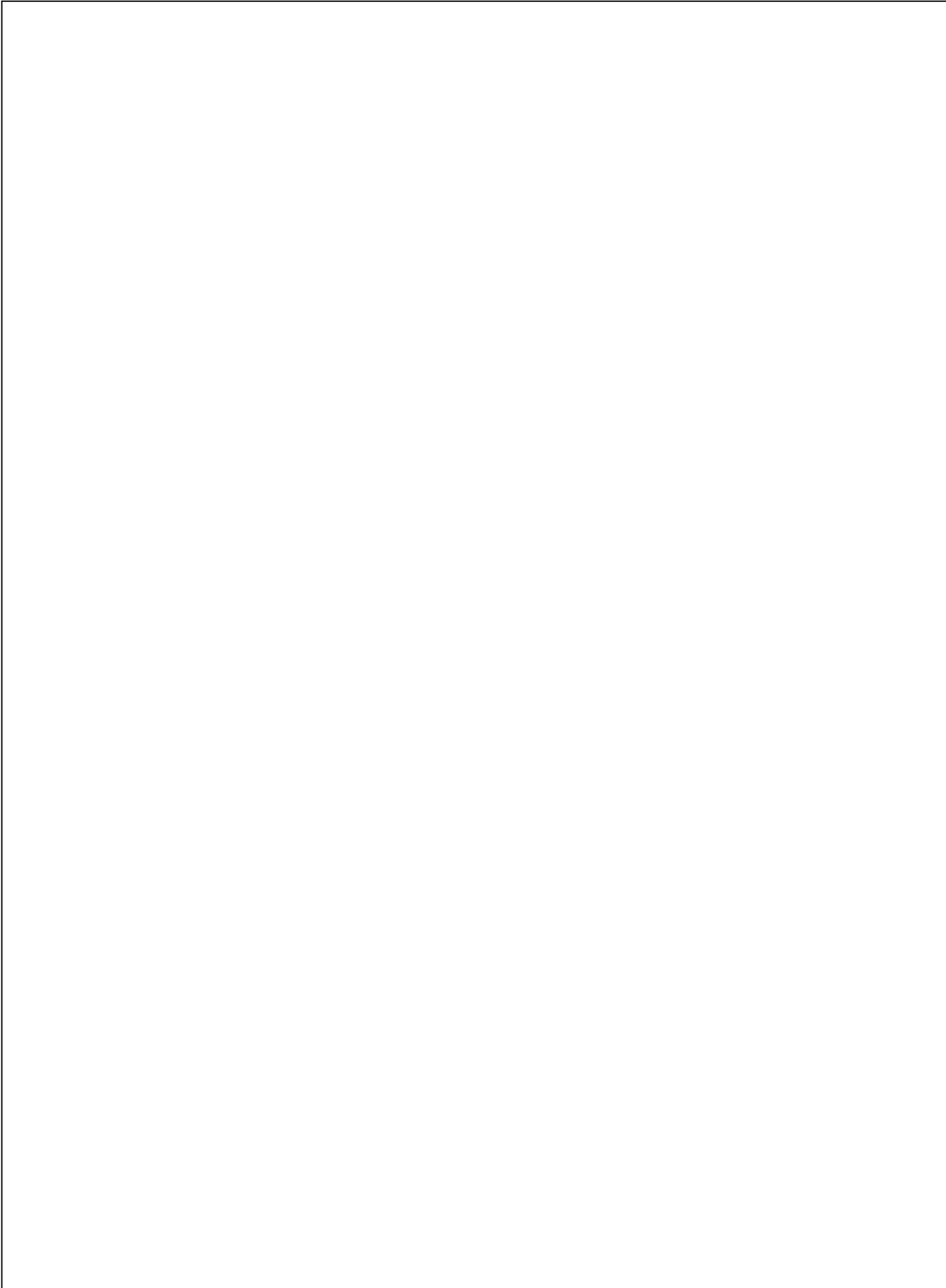

14

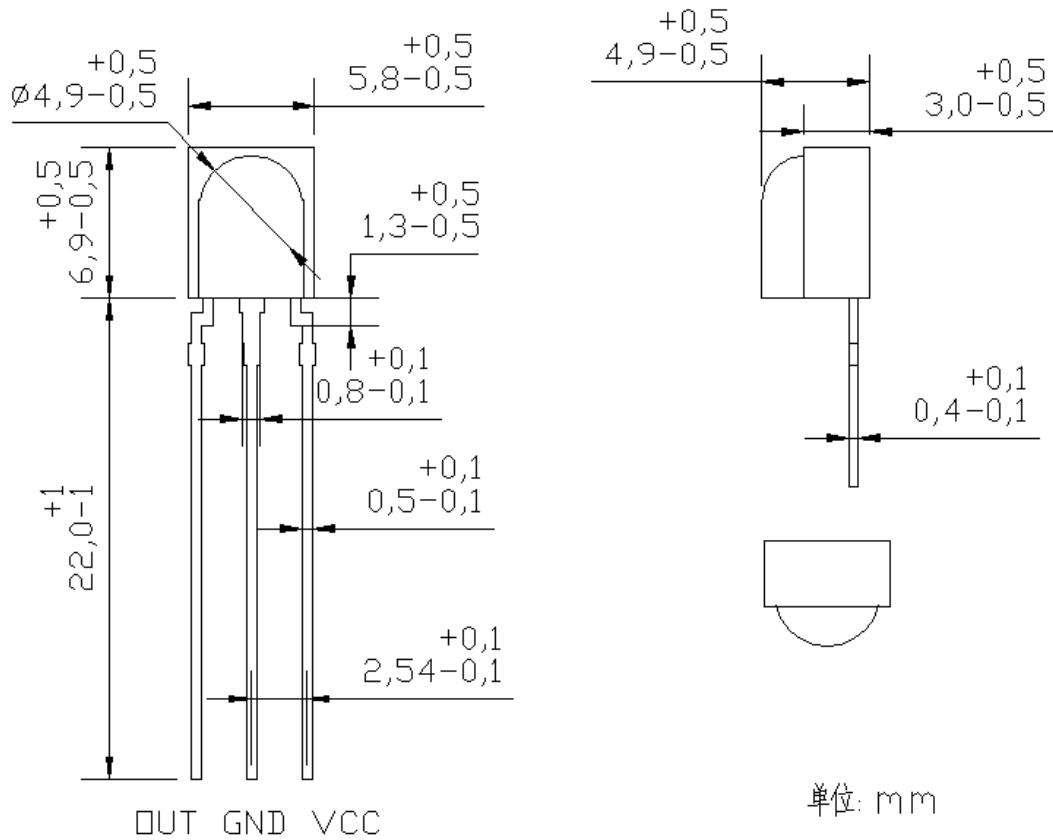

15

1).

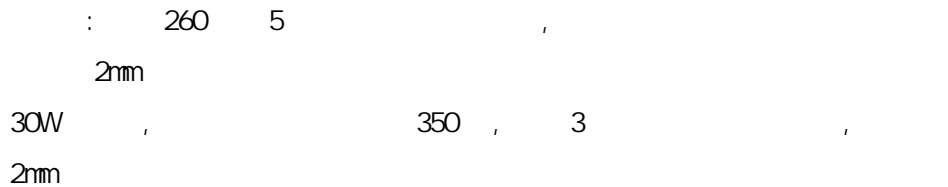

2).

3).



4).

5).

6).

3

7).

TECHNICAL

TECHNICAL ELECTRONICS CO., LTD.

