

LG-T1921RGBA-TD-AL

DATA SHEET

SPEC. NO. : SZ22101501
DATE : 2022/10/15
REV. : A/0

Approved By:

Checked By:

Prepared By:



LG-T1921RGBA-TD-AL

TOP Full-color LED

Catalogue

Electrical Characteristics.....3

Typical Characteristic 1/TT5 51.5 re f isrveTw 9 0D()49 34.256 TD[.2.7321RGB1 TT5 15 0 0 10.5 0

3



T_{Ambient} 25

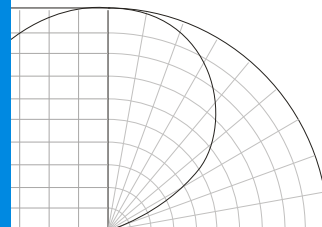

Reliability Test Items And Conditions

实验项目	参考标准	实验条件	时间	样品数	判据
		↔			

Criteria For Judging Damage

测试项目	符号	测试条件	判定标准
			μ
			≧ ≦

Product design and operational recommendation

1 mm

Product design Unit: mm

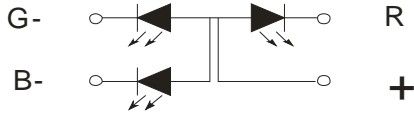
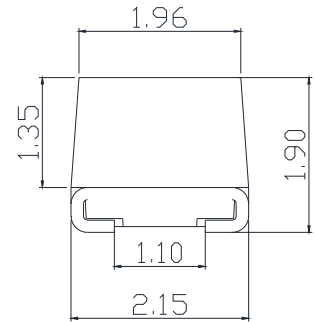
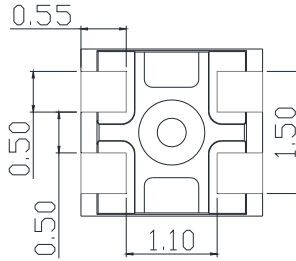
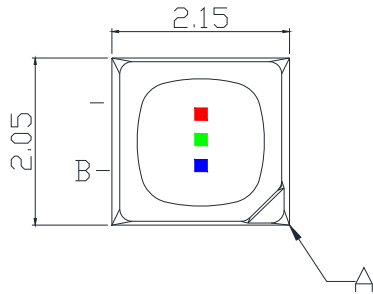

2 mm

Recommended soldering pad (Unit: mm)

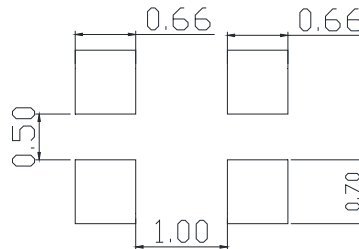

3 0.75mm

Recommendation for glue filling: filling height must be higher than or equal to 0.75mm

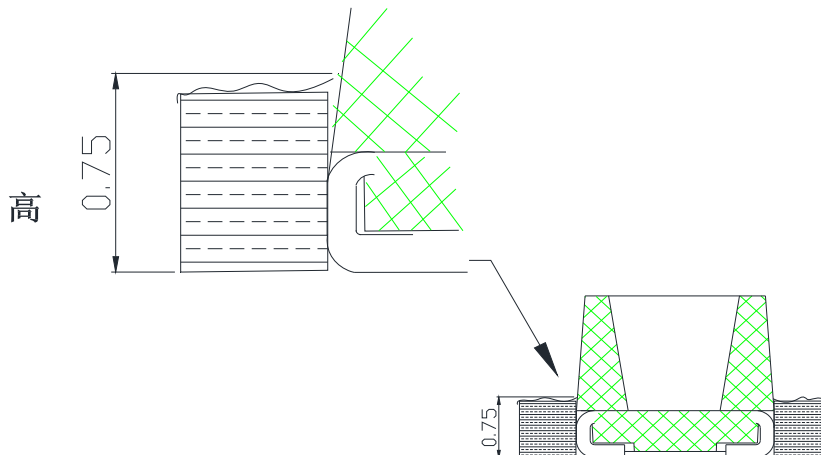

1

Packaging (1)

◇ Carrier Tape

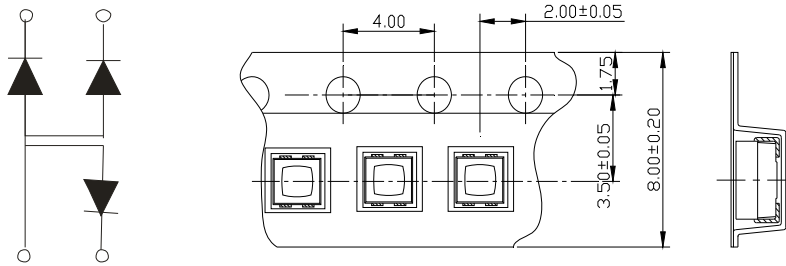

◇ Details Of Carrier Tape

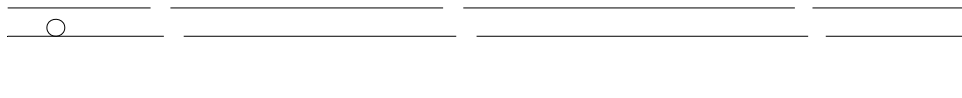
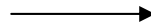

◇ Reel Dimension

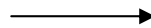

LIGHT

LIGHT ELECTRONICS CO., LTD.

LIGHT

LIGHT ELECTRONICS CO., LTD.



2

Guideline for Soldering (2)

(2)

Precautions (2)

3.

Design Consideration

-

-

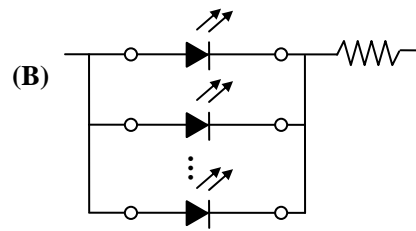
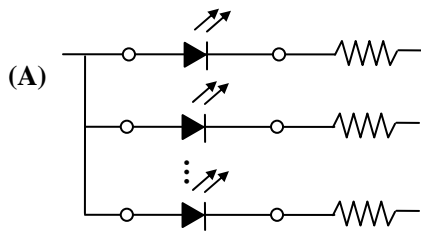

-

4.

Reverse voltage protection

-

